

## Implementation and Applications of a 3D-sensitive Magneto-resistive Sensor

Sarah S. Rabelo, R.S. Sarthour, M.F. Lopes, S.B. Belmonte and I.S. Oliveira  
 Centro Brasileiro de Pesquisas Físicas, Rua Dr. Xavier Sigaud 150, Rio de Janeiro - 22290-180, Brazil

Received on 01 September, 2005; revised received on 08/02/2006

We report the implementation and applications of a commercial magneto-resistive sensor, capable of measuring simultaneously the three cartesian components of a magnetic field, either DC or AC. After calibration procedure, basic tests are made by mapping the magnetic field around a small solenoid. The response of the sensor to a vibrating magnetic sample is then studied in various situations of resonance: (a) continuous vibrating sample; (b) sinusoidal amplitude modulated motion; (c) squared amplitude modulated motion and (d) modulated pulsed signal. This last experiment is rather similar to what is done in the well known technique of Nuclear Magnetic Resonance (NMR). The sensor response in this case resembles the Free Induction Decay, the signal observed in usual NMR experiments. The Fourier transform of such signals reveals the response of different vibrating modes of the system. The high sensitivity of the sensor is tested for mechanical noise, what entitles it to be used in various applications. Computer interfacing is made through the parallel port, and experiments were automated through a LabVIEW routine. Details on the built circuitry for reading from and writing to the sensor are also presented.

Magnetic sensors are one of the main industrial applications of new magnetic materials [1–5]. On this paper we report the implementation and applications of the permalloy-based magneto-resistive sensor HMC2003 from Honeywell. These are made from thin films of Nickel-Iron deposited on Silicon substrate. Three mutually perpendicular stripes of the film, each one arranged in a Wheatstone bridge configuration, are capable of measuring simultaneously the three cartesian components of a magnetic field. The saturation field for this model is 2 G, and its resolution 40  $\mu$ G. Further technical details of the sensor can be found in [6]. The chip containing the sensor is mounted in a board with approximate dimensions  $2 \times 2.5$  cm<sup>2</sup>, which in turn is mounted in a box of  $4.4 \times 3.5 \times 1.6$  cm<sup>3</sup>. The communication with the sensor is made through a PC (Personal Computer) parallel port, and the circuitry to perform this task is shown in Figure 1.

Reading the sensor is carried out through a circuit containing the AD974 Analog to Digital Converter (ADC), from Analog Devices. This acquisition system makes use of four channels for serial communication and presents high sampling speed (200 kHz) and 16 bits resolution. The data acquisition software was developed using the graphical programming package LabVIEW. The values of the measured magnetic field were acquired individually for each spatial direction ( $x$ ,  $y$  and  $z$ ), through one of the input channels of the A/D converter. Due to the high sampling rate, there was no significant change of the magnetic field during the data transfer. Furthermore, since the converter A/D resolution is of 16 bits, it was possible to measure very low values of magnetic fields ( $\sim 60 \mu$ G) using the developed acquisition system described in this paper. For digital filtering process a subroutine was created which averages several measured values, in order to eliminate the random white noise.

The HMC 2003 sensor can be affected by large fluctuating magnetic fields which lead to degradation of output signal. In order to eliminate this effect, and maximize the output signal, a magnetic switching technique can be applied to the bridge using the SR+ and SR- pins that eliminates the effect of past magnetic history. Then a Set/Reset control circuit was

built using the HEXFET IRF7105, from International Rectifier. These circuits are also controlled through the parallel port.

Calibration and linearity tests were carried out through the comparison of the HM2003 sensor to a non-directional commercial Hall effect-based sensor. The directional property of the sensor was verified using a Helmholtz coil, with the field applied along the three directions, although attaining good alignment along the thin edges of the sensor was not simple. Figure 2 exhibits the mapping of the static magnetic field around a solenoid with dimensions  $R = 3D1$  cm,  $L = 3D20$  cm. Two peaks are observed at the extremities of the coil, region where the field is more intense. Due to the size of the sensor box, as compared to the size of the solenoid, measurements between the two peaks inside the solenoid could not be taken.

In order to test the response of the sensor to AC fields, samples of ferrite with different masses were mounted in a glass rod ( $\approx 6$  cm of length and radius  $R \approx 0.5$  mm) and made to vibrate directly above the  $z$ -face of the sensor. Data acquisition was automated through a LabVIEW routine. Figure 3(a) shows the response to a simple sinusoidal signal and its Fourier transform, and Figures 3(b) and 3(c) show the response to amplitude modulated signals, with the respective Fourier transforms. By varying the (unmodulated) frequency, resonance curves can be observed, as in Fig. 4.

From the information of resonance peaks, it was possible to test the sensor in an experiment rather similar to what is done in Nuclear Magnetic Resonance: the carrier was modulated with a square pulse at the resonance frequency of a particular sample (in the case shown, 33 mg), and applied to the system. Separation between pulses was chosen to be a few times the linewidth ( $\Delta\tau \approx 20$ sec.), and pulse width was varied around  $\tau = 3D1/\Delta f_0 \approx 5.5$  sec, where  $f_0 \approx 22$  Hz is the resonance frequency. The results are shown in Figure 5. We observe that the time response is very similar to the so-called Free Induction Decay (FID) of a NMR experiment [7]. As the pulse width is narrowed, the spectra become more complex. This can be attributed to the excitation of different vibrating

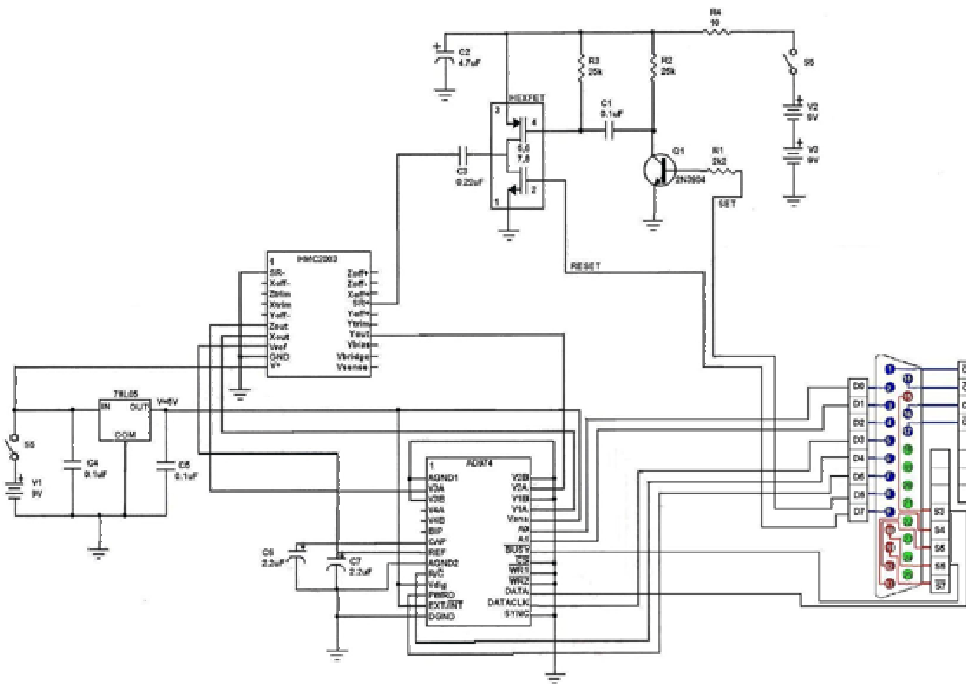

FIG. 1: Circuit board to communicate to the Honeywell HMC2003 sensor.

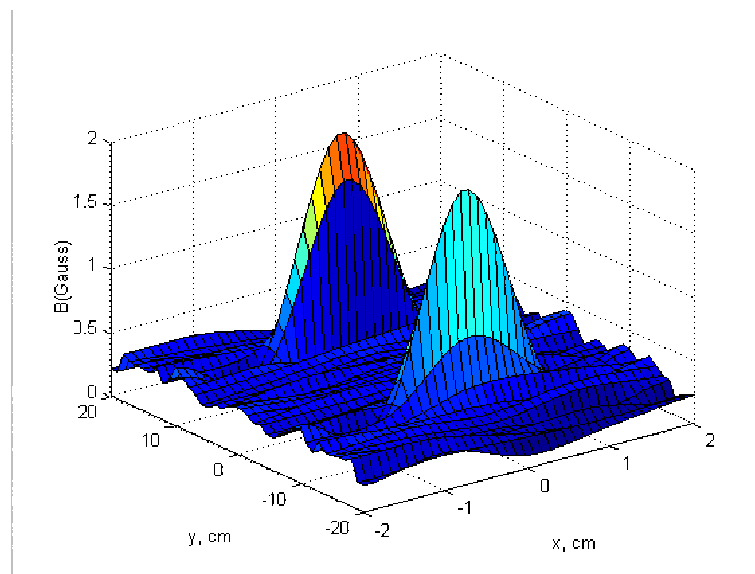

FIG. 2: Mapping of a static field around a solenoid with radius  $R = 1$  cm and length  $L = 20$  cm. The two peaks correspond to the edges of the solenoid. The region in between them was not mapped.

modes of the rod, as the effect of narrowing the pulse is the broadening of its Fourier components. Of course, this information does not appear in the “continuous wave” experiment, in which a single vibrating mode of the rod is excited.

The above results show the excellent time response of the HM2003 sensor to AC fields. This opens up many possibilities of applications. As an example, Figure 6 shows the de-

tection of a mechanical noise applied to the workbench where the sensor was mounted. The setup can be easily extended to operate as a motion sensor of bridges, building, earthquakes, etc. Furthermore, by adapting the data acquisition program and inserting a Global Positioning System (GPS) to the basic setup, a portable device for mapping magnetic fields can be easily mounted.

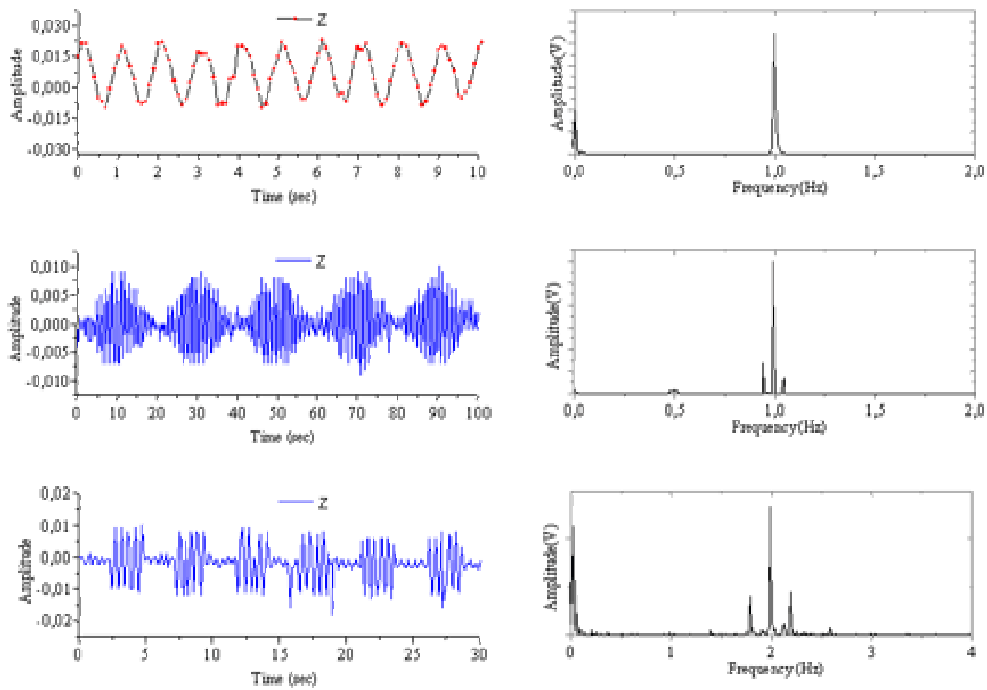

FIG. 3: (a) Response of the sensor to a single sinusoidal signal applied to an oscillating glass rod containing 33 mg of ferrite, and its Fourier transform. (b) and (c) Response to amplitude modulated signals, sinusoidal and square, respectively, and their Fourier transforms.

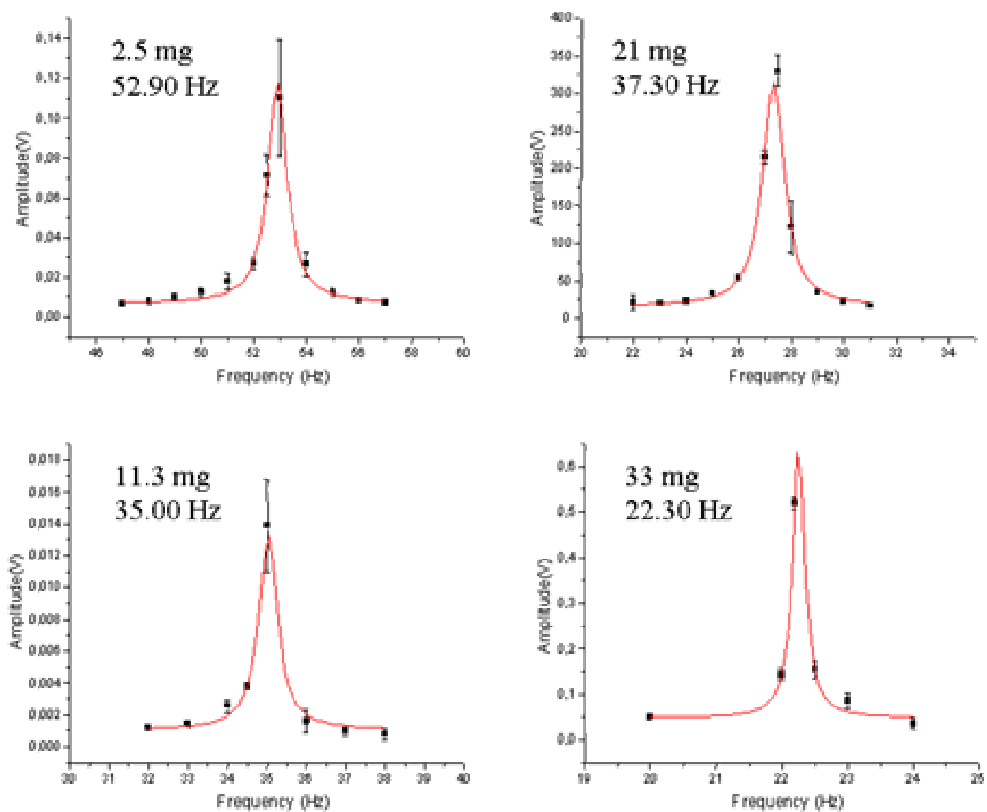

FIG. 4: Resonance curves, varying the excitation frequency point-by-point, for different masses of ferrite samples.

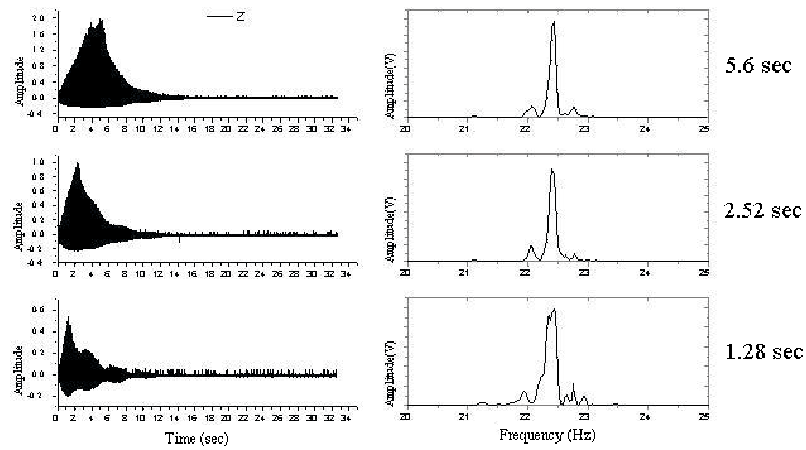

FIG. 5: Response to squared modulated pulses for various pulse-widths applied to the sample of 33 mg. The experiment is similar to what is done in Nuclear Magnetic Resonance.

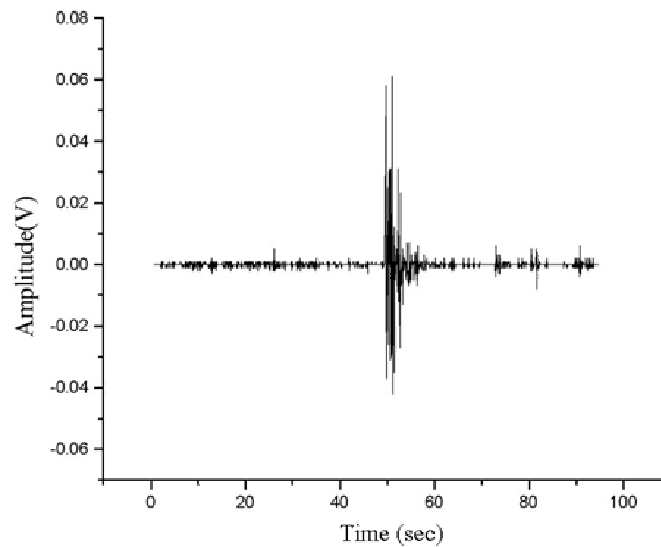

FIG. 6: Detection of mechanical noise in the workbench.

- 
- [1] A.P. Guimaraes, *Magnetism and Magnetic Resonance in Solids*, John Wiley & Sons, Inc., **1998**.
  - [2] O’Handley, *Magnetic Materials–Magnetism*, John Wiley & Sons, Inc., New York, **2000**.
  - [3] Park DG, Moon EJ, Rheem YW, Kim CG, Hong JH, *The GMI profiles of surface-removed amorphous ribbon*, Physica B-Condensed Matter, **327**(2-4): p.357-359, **2003**.
  - [4] Mao XH, Zhou Y, Chen JA, Yu JQ, Cai BC, *Giant magnetoimpedance and stress-impedance effects in multilayered Fe-SiB/Cu/FeSiB films with a meander structure*, Journal of Materials Research, **18**(4): p.868-871, **2003**.
  - [5] Cai CA, Usami K, Hayashi A, Mohri K, *Frequency-modulation-type MI sensor using amorphous wire and CMOS inverter multivibrator*, IEEE Transactions on Magnetics, **40**(1): p.161-163, **2004**.
  - [6] Honeywell SSEC, *Three-Axis Magnetic Sensor Hybrid*, <http://www.ssec.honeywell.com/magnetic/datasheets/hmc2003.pdf>
  - [7] F. Fukushima and S.B.W. Roeder, *Experimental Pulse NMR. A Nuts and Bolts Approach*, Eddison Wesley (Reading 1981)